

AGF

Agitation, mixing and dispersion

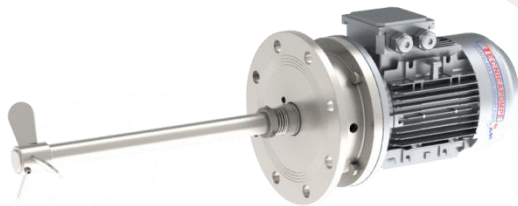

PRESENTATION



Range of stainless steel sanitary fixed stirrers, for mixing food and pharmaceutical fluids inside tanks and autoclaves both under pressure and vacuum.

They can be installed at different angles depending on the desired movement effect and available in a wide variety of standard versions or can be customized by adapting the rotation speed, the length of the axis, the shape of the impellers and the number of stages.

APPLICATIONS



Water treatments



Beer



Winery



Dairies



Chemical and pharma

TECNICAL DATA

Connections	Flange (DIN2632/33 regulation)	Impeller	Open, 3 nautical blades, with 1 or more stages
Materials	AISI 316L (1.4404) for parts in contact with the product, AISI 304L (1.4304) for parts of the support. Additional stainless steel configurations available on request	Maximum pressure	Up to 15 Bar on standard versions
Mechanical seal and gaskets	Single internal execution for lateral installations of the agitator, materials of the tracks and elastomers according to the fluid to be mixed Stationary seal gasket for vertically installed agitators	Temperature	Between -20°C e +180°C Other outer range temperatures on request
Frame	Monobloc with B5 flange and shaft integral with the motor axis Independent support with shielded bearing and shaft keyed on the motor axis. Possibility of using a gearmotor to reduce the number of revolutions	Viscosity	Up to 500 cP
Motor	3ph, 6-pole IEC standard, insulation class according to the fluid temperature. ATEX execution or with specific regulations (UL-CSA, NEMA) is also possible on request	Suspended solids	For clean liquids. For specific applications, the usage limits with suspended solids are indicated on the pump technical data sheet

AGF standard series - EMPLOYMENT DATA

Model	Power [kW]	Speed [rpm]	Tank volume [m ³]
AGF 037	0,37	900	2 - 7
AGF055	0,55	900	7 - 10
AGF 075	0,75	925	10 - 15
AGF 11	1,1	945	15 - 20
AGF 15	1,5	955	20 - 35
AGF 22	2,2	960	35 - 60
AGF 30	3	960	50 - 70
AGF 40	4	960	70 - 100
AGF 55	5,5	960	80 - 120

AGF standard series - WEIGHT & DIMENSIONS

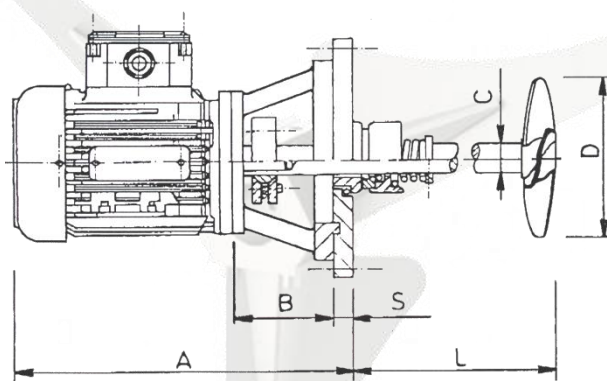

Model	A	B	C	*D	*L	S	Tank connection flange DIN 2623/33	Weight [kg]
AGF 037	298	50	25	125	400	18	DN 100	22
AGF055	298	50	25	150	400	18	DN 100	24
AGF 075	320	50	30	175	400	18	DN 100	28
AGF 11	348	60	30	180	500	18	DN 100	29
AGF 15	360	60	35	200	500	18	DN 150	34
AGF 22	392	60	35	225	500	18	DN 150	39
AGF 30	420	60	40	250	500	18	DN 150	46
AGF 40	451	60	45	300	600	18	DN 150	78
AGF 55	489	60	45	325	600	18	DN 150	89

* The dimensions marked with an asterisk can be adapted during the design phase to adapt them to the specific needs of use.

www.tecnicapompe.com